

SunPower® P19-320-BLK

SunPower® Performance Panel for Residential Installations

SunPower Performance Panels wrap front contact cells with 30+ years of SunPower materials and manufacturing expertise. The weakest points of Conventional Panel design are eliminated to deliver superior power, reliability, value and savings.¹



Engineered for Performance

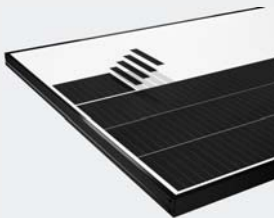

Innovative Design

- Robust and flexible cell connection technology. Outstanding reliability.
- Conductive adhesive, proven in the aerospace industry.
- Redundant cell to cell connections.

Proven Performance



- Named as a Top Performer in all DNV/GL reliability tests.
- Reduced panel temperature due to unique electrical bussing.



High Power

Enhanced active area and monocrystalline cells increase power and savings while designing out fragile ribbons and solder bonds on the cells.



High Performance

Up to 28% more energy in the same space over 25 years.² Outperforms Conventional Panels in partial shade thanks to unique parallel circuitry. Proprietary bussing design limits power loss, maximizing production during morning and evening shading or soiling.



Premium Aesthetics

SunPower® Performance Panels with their black frame and black backsheets blend harmoniously into your roof and add elegance to your home.



High Reliability

SunPower Performance Panels are the most deployed shingled solar panel in the world.³ Innovative cell shingling mitigates the leading reliability challenges associated with conventional front contact panels by designing out fragile ribbons and solder bonds on the cells. SunPower stands behind its panels with its industry-leading Complete Confidence Warranty.



25 Year Combined Warranty

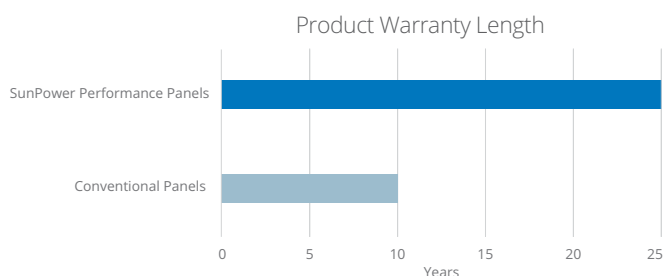

P19-320-BLK: SunPower® Performance Panel for Residential Installations

Electrical Data						
Model	SPR-P19-335-BLK	SPR-P19-330-BLK	SPR-P19-325-BLK	SPR-P19-320-BLK	SPR-P19-315-BLK	SPR-P19-310-BLK
Nominal Power (P _{nom}) ⁴	335 W	330 W	325 W	320 W	315 W	310 W
Power Tolerance	+5/-0%	+5/-0%	+5/-0%	+5/-0%	+5/-0%	+5/-0%
Efficiency	19.9%	19.6%	19.3%	19.0%	18.7%	18.4%
Rated Voltage (V _{mpp})	37.5 V	37.2 V	36.9 V	36.4 V	35.9 V	35.4 V
Rated Current (I _{mpp})	8.94 A	8.87 A	8.80 A	8.79 A	8.77 A	8.76 A
Open-Circuit Voltage (V _{oc})	44.8 V	44.6 V	44.4 V	43.9 V	43.7 V	43.2 V
Short-Circuit Current (I _{sc})	9.51 A	9.44 A	9.37 A	9.35 A	9.33 A	9.28 A
Maximum System Voltage	1000 V IEC					
Maximum Series Fuse	18 A					
Power Temp. Coef.	-0.37% / °C					
Voltage Temp. Coef.	-0.29% / °C					
Current Temp. Coef.	0.05% / °C					

Tests And Certifications	
Standard Tests ⁵	IEC 61215, IEC 61730
Quality Certs	ISO 9001:2008, ISO 14001:2004
EHS Compliance	OHSAS 18001:2007, Recycling Scheme
Available Listings	TUV

Operating Condition And Mechanical Data	
Temperature	-40°C to +85°C
Impact Resistance	25 mm diameter hail at 23 m/s
Solar Cells	Monocrystalline PERC
Tempered Glass	High-transmission tempered anti-reflective
Junction Box	IP-67, Multi-Contact (MC4), 3 bypass diodes
Weight	18.7 kg
Max. Load	Wind: 2400 Pa, 245 kg/m ² front & back Snow: 5400 Pa, 550 kg/m ² front
Frame	Class 1 black anodized (highest AAMA rating)
Blocking Diode	None

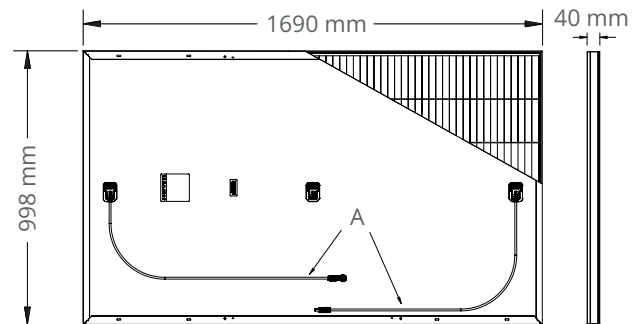

FRAME PROFILE

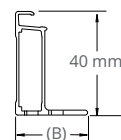

(A) Cable Length: 1200 mm +/-15 mm
 (B) Long Side: 32 mm
 Short Side: 24 mm

REFERENCES:

- 1 Independent Shade Study by CPV Laboratory. 2016.
- 2 SunPower 320 W compared to a Conventional Panel on same sized arrays (260 W, 16% efficient, approx. 1.6 m²), 0.6%/yr degradation (Leidos technical review 2017).
- 3 Osborne. "SunPower supplying P-Series modules to a 125MW NextEra project." PV-Tech.org. March 2017."
- 4 Measured at Standard Test Conditions (STC): irradiance of 1000 W/m², AM 1.5, and cell temperature 25° C.
- 5 Class C fire rating per IEC 61730.

Designed in USA, assembled in China.

See www.sunpower.com.au/company for more reference information. Specifications included in this datasheet are subject to change without notice.

©2018 SunPower Corporation. All rights reserved. SUNPOWER and the SUNPOWER logo are registered trademarks of SunPower Corporation in Europe, the U.S., and other countries as well.

Read safety and installation instructions before using this product.

SUNPOWER®